

ASSEMBLY AND INSTALLATION INSTRUCTIONS

T0108

WARNING: Turn off the main power at circuit breaker before installing fixture.
AVERTISSEMENT: Coupez la source d'alimentation principale au panneau central de disjoncteurs avant d'installer le luminaire.

NOTES: 1. Before installing, consult local electrical codes for wiring and grounding requirements.
2. READ AND SAVE THESE INSTRUCTIONS.

Hardware Package (included):

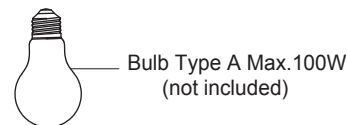
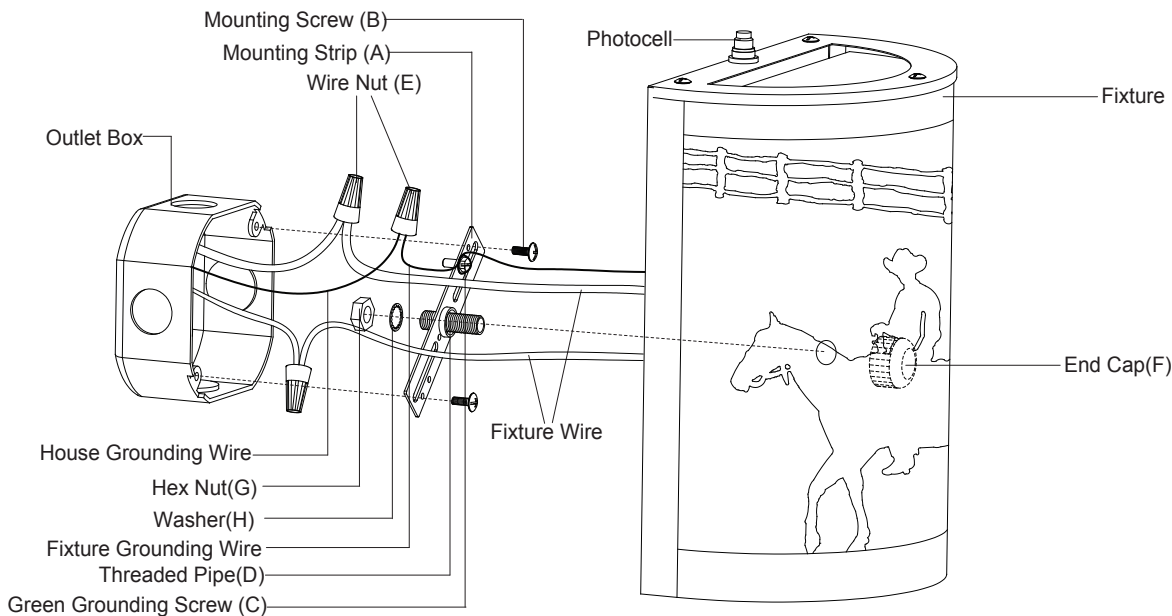
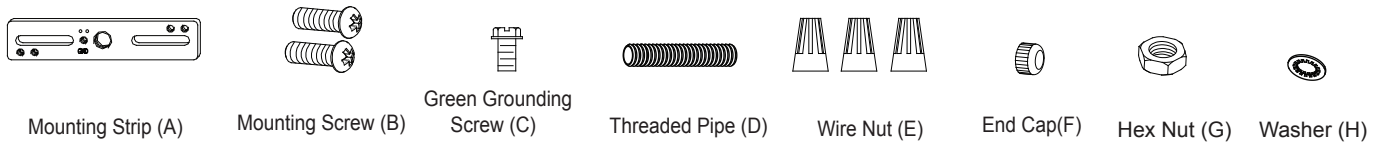

IMPORTANT:

The sensor has an excellent photocell function to enable the light to turn on at dusk and off at dawn automatically.

Installation Steps

Turn off the power at fuse or circuit box.

1. Attach the threaded pipe to the mounting strap, then secure it with a washer and hex nut.
2. Attach the mounting strap to the outlet box by using two mounting screws.
3. Pull out the source wires from the outlet box. Make wire connections using wire nuts as follow:
 - Connect the hot wire (usually black insulation) from the fixture to the black wire from the power source.
 - Connect the neutral wire (usually white insulation) from the fixture to the white wire from the power source.
 - Attach the fixture grounding wire (usually green insulation or bare wire) to the mounting strap with the green grounding screw. Then connect it to the house grounding wire with the wire nut.Carefully put the wires back into the outlet box.

4. Attach the fixture to the mounting strap by inserting threaded pipe, then secure it with end cap.

NOTE: With silicone caulking compound, caulk completely around where the back side of the fixture meets with the wall surface to prevent water from seeping into the outlet box.

5. Install a bulb (not included). See relamping label on socket area or packaging for maximum allowed wattage.

Turn on the power at fuse or circuit box.

Operation the Unit Without Photocell

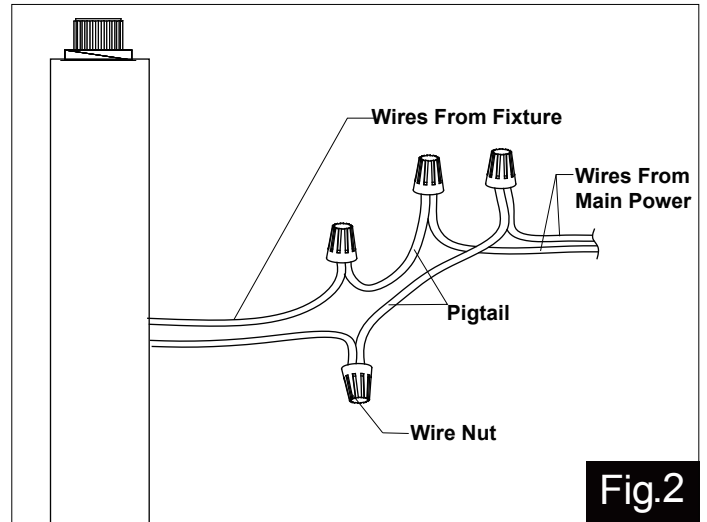
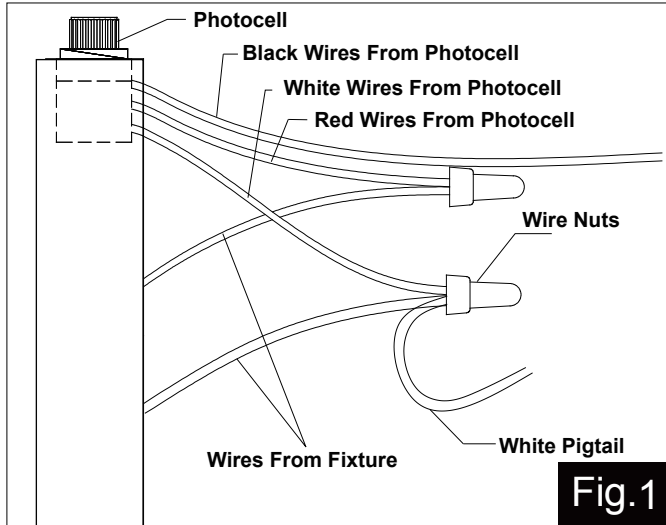

1. Turn off the power at the fuse or circuit box before starting installation.

2. Loosen the wire nuts connected with the wires from photocell. (See Fig.1)

Note: Do not move the photocell to prevent water from seeping into the outlet box.

3. Take a white pigtail and black pigtail and make wire connections using wire nuts: (See Fig.2)

- The black wire from the fixture to one end of the black pigtail.
 - The white wire from the fixture to one end of the white pigtail.
 - The other end of the black pigtail to the black wire from the power source.
 - The other end of the white pigtail to the white wire from the power source.
- Put all wires back into the back plate of the fixture.

The following parts are available for re-order if damaged or missing.

Spare Parts List:

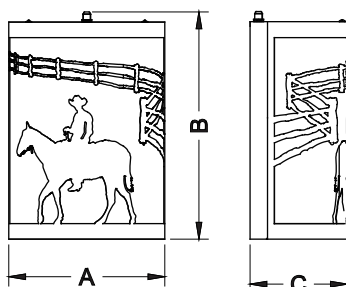
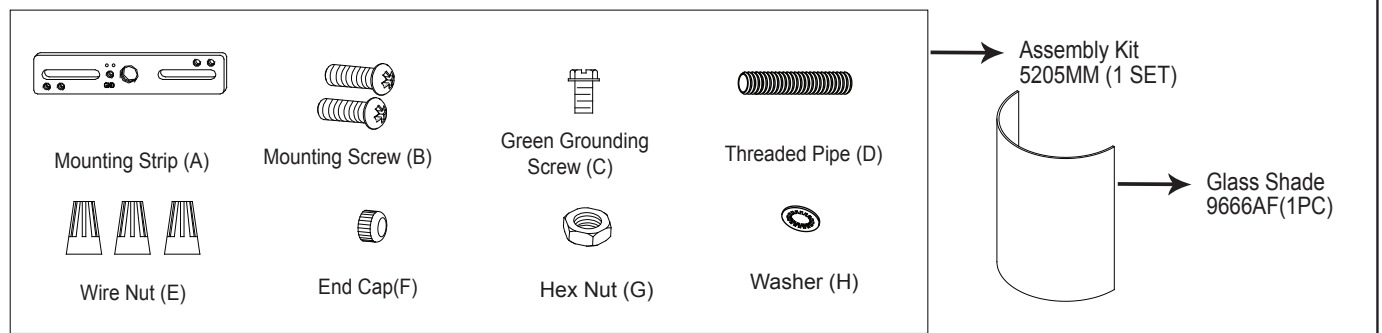

A: 8"

B: 11"

C: 5"

VAXCEL

150113